

REVISIONS					
REV	ECO	DESCRIPTIONS	DWN	CKD	APVD
A	-	RELEASE TO ECO CONTROL	WPM 6/1/00	RWN 6/5/00	JAM 6/5/00
B	04004	ADDED SHEET 2	GPG 7/5/01	JG 8/10/01	JAM 8/23/01
C	04451	UPDATED PER ECO	DMS 6/7/02		

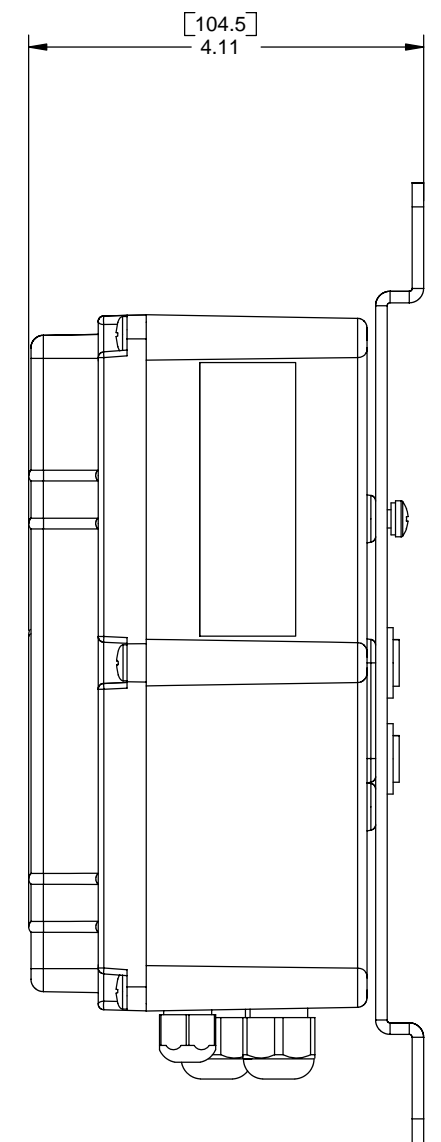
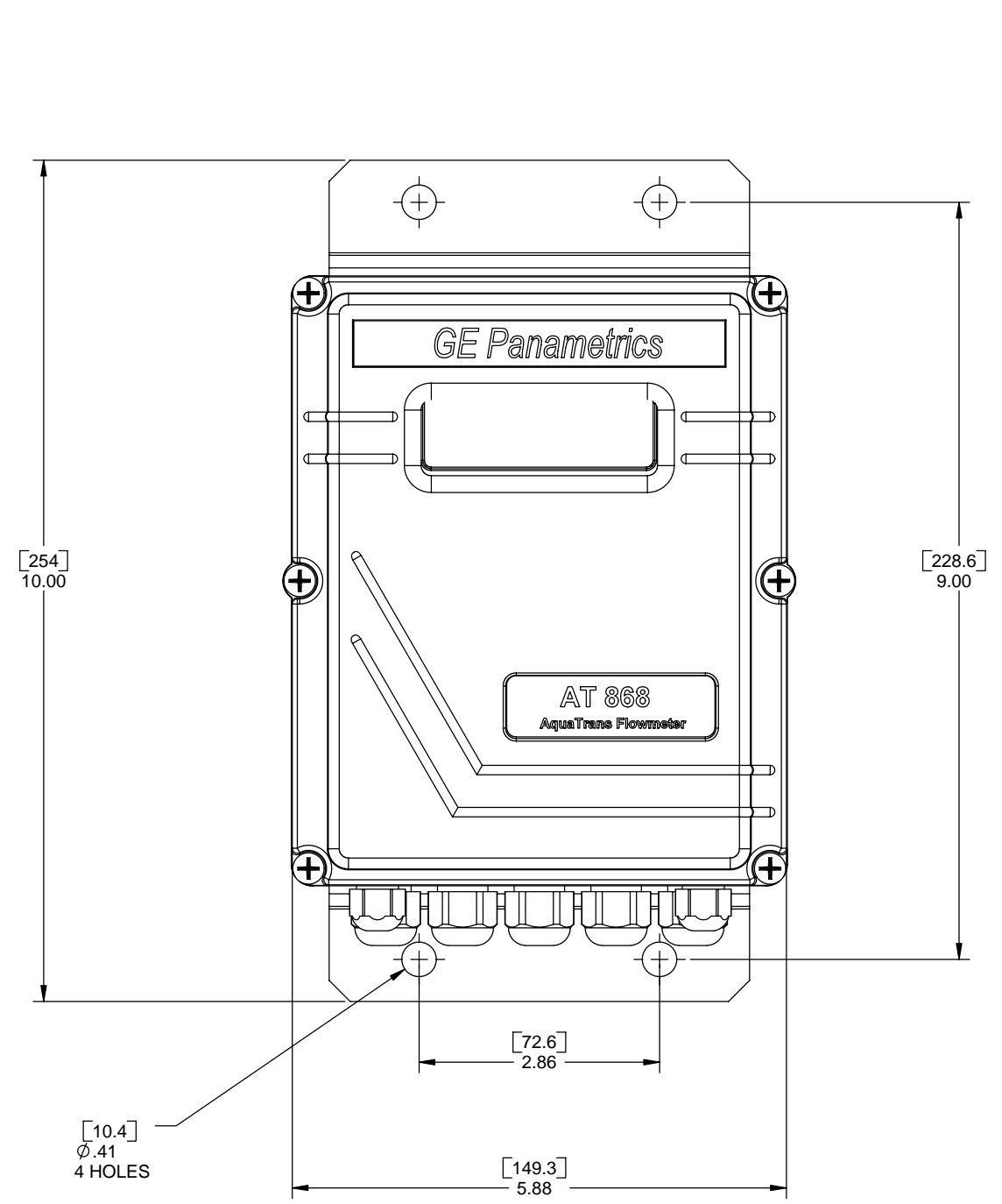

WALL MOUNT

NOTES:
1. ALL DIMENSIONS ARE INCHES [MM]

TOLERANCES FOR INCHES FRACTIONS DECIMALS ANGLES ± 1/32 .XX ± .01 ± 1° .XXX ± .005		THIRD ANGLE PROJECTION 		 PANAMETRICS Waltham, Mass. 02453-3497 www.panametrics.com	
TOLERANCES FOR MILLIMETERS DECIMALS ANGLES .XX ± .2 ± 1° .XXX ± .12		APPROVALS DATE		TITLE	
SURFACE FINISH 125		DRAWN W MORRIS 5/3/00		OUTLINE & INSTALLATION UPT/AT 868	
DO NOT SCALE THIS DRAWING		CHECKED RWN 6/5/00		DRAWING NUMBER	
DO NOT SCALE THIS DRAWING		ENGINEER J MAFFE 6/5/00		712-1106	
DO NOT SCALE THIS DRAWING		RN 5137		REV C	
REV	ECO	MODEL NO.	UPT/AT 868	SCALE 1:1	SHEET 1 OF 2

REVISIONS					
REV	ECO	DESCRIPTIONS	DWN	CKD	APVD
A	-	RELEASE TO ECO CONTROL	WPM 6/01/00	RWM 6/05/01	JAM 6/05/01
B	04004	ADDED SHEET 2 TO ECO CONTROL	GPC 8/02/01	JG 8/10/01	JAM 8/23/01
C	04451	UPDATED PER ECO	DMS 6/7/02		

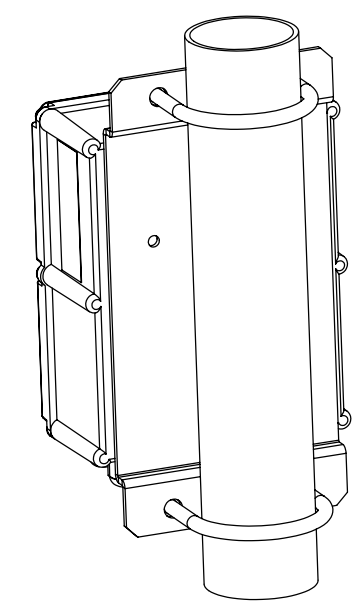
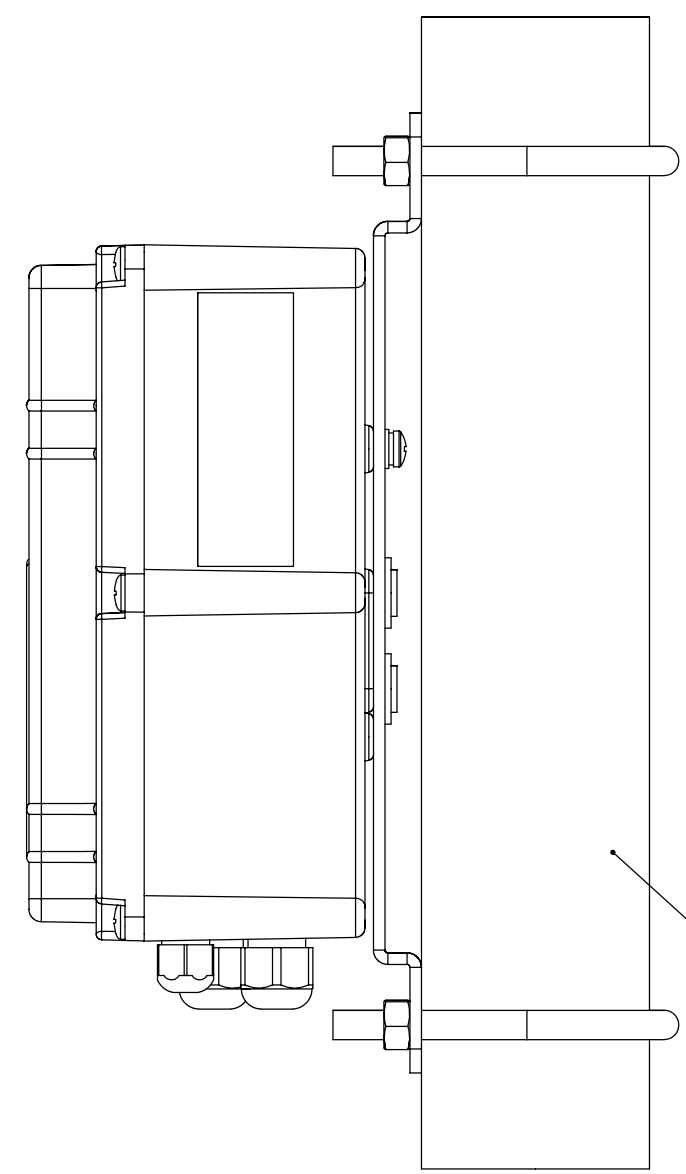
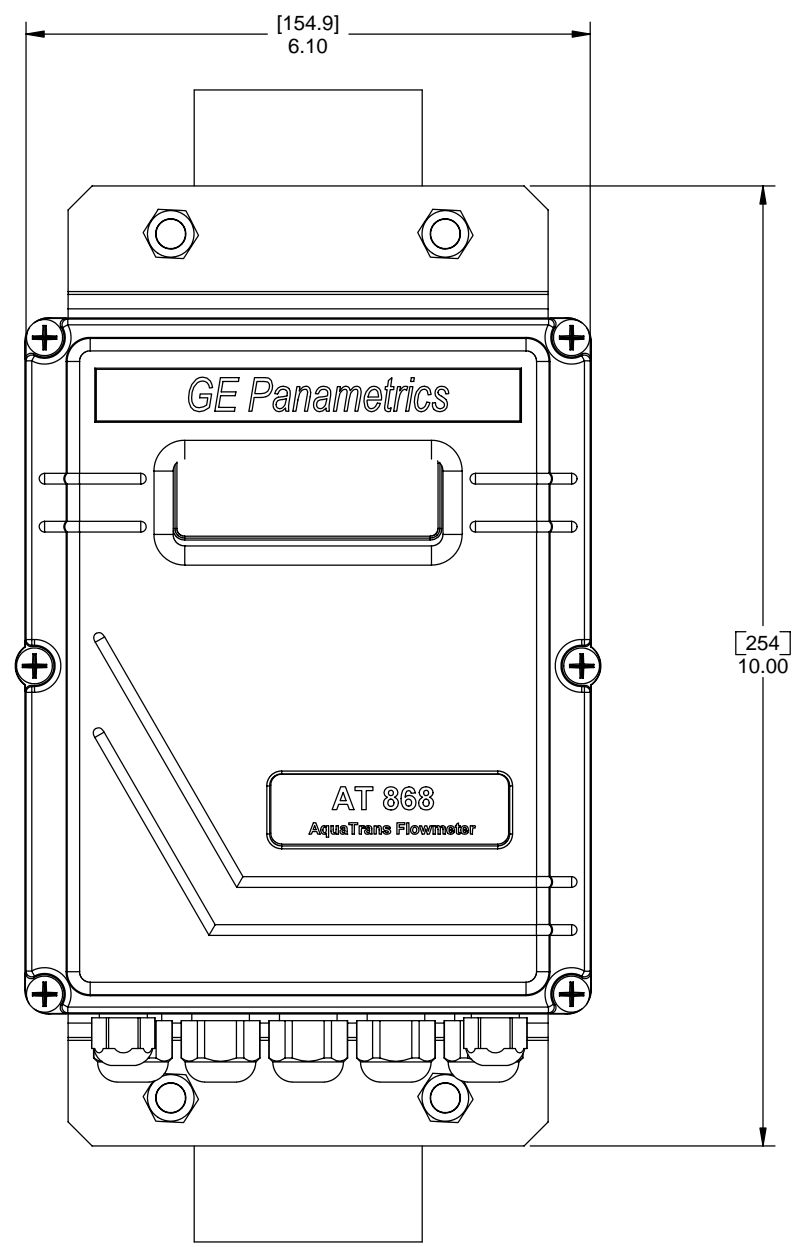

NOTE:
2" DIA PIPE AND U-BOLT'S
SHOWN FOR REFERENCE ONLY

PIPE MOUNT

NOTE:
REF: DIMENSIONS ARE INCHES [MM]

TOLERANCES FOR INCHES		THIRD ANGLE PROJECTION		 PANAMETRICS Waltham, Mass. 02453-3497 www.panametrics.com	
FRACTIONS	DECIMALS	ANGLES	APPROVALS	DATE	TITLE
± 1/32	.XX ± .01	± 1°	DRAWN W MERRIS	5/3/00	OUTLINE & INSTALLATION UPT/AT 868
	.XXX ± .005		CHECKED RWN	6/5/00	
TOLERANCES FOR MILLIMETERS		SURFACE FINISH		ENGINEER JAM	DATE 6/5/00
DECIMALS	ANGLES	125	✓	JAM	6/5/00
.XX ± 2	± 1°				
.XXX ± .12					
C	04451	DO NOT SCALE THIS DRAWING	5137	SIZE D	DRAWING NUMBER 712-1106
B	04004	CAD GENERATED DRAWING DO NOT MANUALLY UPDATE	MODEL NO. UPT/AT 868	SCALE 1:1	DO NOT SCALE DWG
A	#				SHEET 2 OF 2
REV	ECO				