

# 21022 Dual Axial Probe Housing Assembly

Bently Nevada\* Asset Condition Monitoring

---

## Description

The 21022 Dual Axial Probe Housing Assembly consists of two proximity probes installed in an externally mounted protective enclosure. It is intended for mounting on the end of a machine nearest the thrust bearing to allow both probes to observe the end of the shaft for axial thrust position movement. The enclosure mounts on the machine case using four standard machine screws. The probes are mounted in sleeve/adaptor assemblies, which are installed directly onto the machine case through two 3/4-in NPT threaded holes.

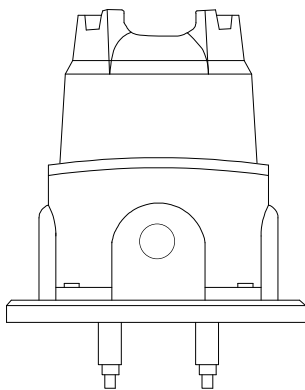

The dual axial position housing meets the American Petroleum Institute's (API) 670 Standard for axial thrust position transducer housings. The external mounting allows probe adjustments from outside the machine, while protecting the proximity probes, probe leads, and extension cables from dust, splashing liquid, or other environmental factors. A removable cover on the enclosure provides access for setting the probe gaps.

---

## Specifications

### Mechanical

#### Housing

#### Material

#### 21022:

Aluminum alloy housing (sand cast, 0.3% copper free) with sleeves fabricated from 304 stainless steel.

#### 164935:

Stainless steel 316L housing with sleeves fabricated from 304 stainless steel.

#### Total housing weight (typical):

3.6 kg (8 lb)

#### Temperature Range:

3300 XL 8 mm -  
or-3300 XL 11  
mm probe:

-51°C to +177°C (-60°F to +351°F).

---

**Note:** Exposing the 3300 XL 8mm or 11mm probe to temperatures below -34°C (-30°F) may cause premature failure of the probe pressure seal.

---

---

## Ordering Information

21022 -AXX-BXX-CXXX-DXX Standard version

164935-AXX-BXX-CXXX-DXX Stainless steel

A: Probe Option, With Connector

- 00 Probe not required
- 12 3300 XL 8 mm probe
- 26 3300 XL NSv\* Probe
- 27 3300 XL NSvProbe, Multiple approvals
- 28 3300 XL 8 mm probe, Multiple approvals
- 29 3300 XL 11 mm probe
- 30 3300 XL 11 mm probe, Multiple approvals

---

**Note:** If option 00 (probe not required) is selected for Option A, then Option B (Probe Cable Length Option) must also be 00.

---

B: Probe Cable Length Option

- 00 Probe cable not required
- 05 0.5 metre (20 in)
- 10 1.0 metre (39 in)

---

**Note:** 3300 XL 11mm Probe not available with 0.5 meter Probe Cable Length.

---

C: Probe Penetration Option

Probe penetration dimensions greater than 305 mm (12 in) require additional sleeve support near the probe to prevent a resonance from occurring. Sleeve adjustment range is ±13 mm (±0.5 in).

Order in increments of 0.1 in (2.54 mm) for 21022; for UK0104, order in increments of 0.5 in (13 mm).

#### Minimum length:

1.0 in (25 mm) = **0 1 0**

for all probes except 3300 XL 11mm,

1.2 in (30.5 mm) = **0 1 2**

for 3300 XL 11mm Probes

**Maximum length:** 12.0 in (305 mm) = **1 2 0**

---

**Note:** For penetration lengths between 1.0 and 2.0 inches, counter-bore may be required in machine case to reduce probe side view and/or rear view effects.

---

D: Fittings Option

- 00 Without fittings
- 01 One 3/4-14 NPT fitting; three 3/4-14 NPT plugs
- 02 Two 3/4-14 NPT fittings; two 3/4-14 NPT plugs
- 03 Two 3/4-14 NPT fittings; two cable seal grips with grommets for cable sizes 1/8-in to 3/16-in, 1/4-in to 5/16-in, 5/16-in to 3/8-in; two 3/4-14 to 1/2-14 NPT reducers
- 04 Three 3/4-14 NPT plugs

---

**Note:** Fittings option -01 thru -04 are supplied as a kit and are not installed when the housing is shipped.

---

## Accessories

### Individual Sleeve

40467-0000-BXXXX

#### B: Probe Penetration Length

This option is the probe sleeve length in 0.01 in. Only order this option in increments of 0.1 in (the last digit of this option is always 0).

Use the following table to determine the probe penetration length if the original housing part number is known:

A option from 21022 or UK0104 Dual Axial Housing part number	Calculation if original part number is known
All options	<p><b>B</b> = Probe penetration option from original housing (21022 option <b>C</b>) + <b>0 1 6 0</b>.</p> <p>Example: original part number is 21022-12-10-040-00.</p> <p><b>B option</b> for replacement sleeve is (0400 + 0160) = <b>0560</b>.</p>

If the original options for the housing are unknown, measure the total probe sleeve length (do not include the probe tip length). For option B, use the following formula:

$$B = (\text{total probe sleeve length}) - (2.4).$$

**Example:** Probe sleeve measures 6 inches long. B option for the individual sleeve equals (0600-0240), or 0 3 6 0.

### Minimum Probe Sleeve Penetration Length (option B):

All probes except NSv and 11mm:  
2.6 in (66 mm)= 0 2 6 0

3300 XL Nsv:  
2.7 in (69 mm)= **0 2 7 0**

3300 XL 11mm:  
2.0 in (51mm)= 0 2 0 0

### Maximum Probe Penetration Length:

All probes:  
13.6 in (345 mm) = **1 3 6 0**

### Spare 3300 XL 8 mm Reverse Mount Probe, 3/8-24 UNF threads

330105-02-12-CXX-DXX-EXX

#### C: Total Length Option

**05** 0.5 metre (1.6 feet)  
**10** 1.0 metre (3.3 feet)  
**15** 1.5 metre (4.9 feet)  
**20** 2.0 metres (6.6 feet)  
**50** 5.0 metres (16.4 feet)  
**90** 9.0 metres (29.5 feet)

#### D: Connector Option

**00** Connector not installed  
**02** Miniature ClickLoc® coaxial connector

#### E: Agency Approval Option

**00** Not required  
**05** Multiple Approvals

### Spare 3300 XL NSv Reverse Mount Probe, 3/8-24 UNF threads

330906-02-12-CXX-DXX-EXX

#### C: Total Length Option

**05** 0.5 metre (1.6 feet)  
**10** 1.0 metre (3.3 feet)  
**50** 5.0 metres (16.4 feet)  
**70** 7.0 metres (22.9 feet)

#### D: Connector Option

**00** Connector not installed  
**02** Miniature ClickLoc coaxial connector

#### E: Agency Approval Option

**00** Not required  
**05** Multiple Approvals

---

**Spare 3300 XL 11 mm Reverse Mount Probe, 3/8-24 UNF threads**

**330705-02-18-CXX-DXX-EXX**

**C: Total Length Option**

- 10** 1.0 metre (3.3 feet)
- 50** 5.0 metres (16.4 feet)
- 90** 9.0 metres (29.5 feet)

**D: Connector Option**

- 00** Connector not installed
- 02** Miniature ClickLoc coaxial connector

**E: Agency Approval Option**

- 00** Not required
- 05** Multiple Approvals

# Dimensional drawing

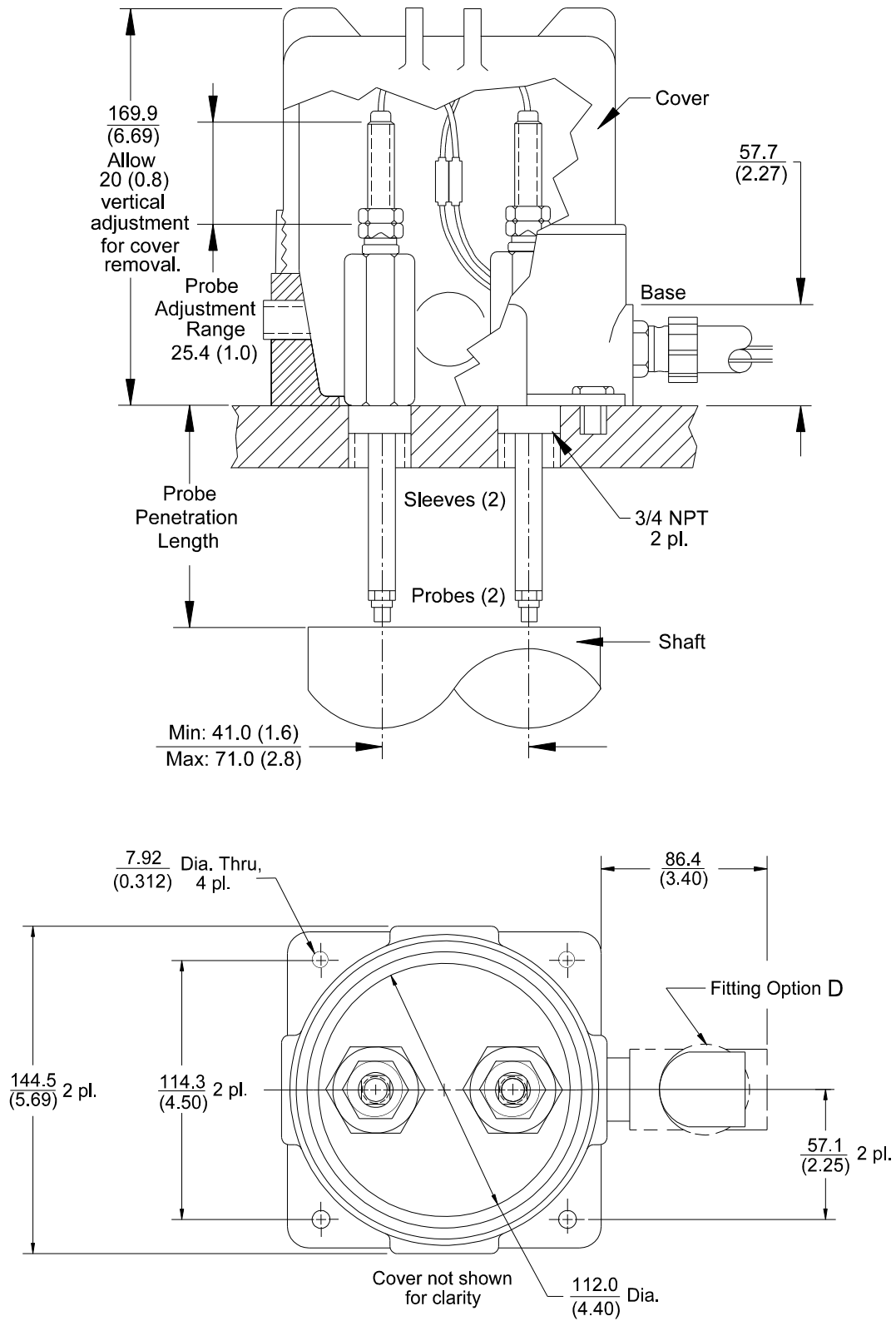

**Figure 1: 21022 Dual Axial Probe Housing Assembly Dimensions**  
 Dimensions are in millimetres (inches)

\* Denotes a trademark of Bently Nevada, Inc., a wholly owned subsidiary of General Electric Company:  
Bently Nevada, NSv and ClickLoc.

© 2000 – 2012 Bently Nevada, Inc. All rights reserved.

Printed in USA. Uncontrolled when transmitted electronically.

1631 Bently Parkway South, Minden, Nevada USA 89423

Phone: 775.782.3611 Fax: 775.215.2873

[www.ge-mcs.com/bently](http://www.ge-mcs.com/bently)